

THIS DRAWING IS UNPUBLISHED. RELEASED FOR PUBLICATION
 © COPYRIGHT - By - ALL RIGHTS RESERVED.

REVISIONS				
P	LTR	DESCRIPTION	DATE	APVD
B		UPDATE PER ECO-16-002588	24 FEB 16	CAS CAS

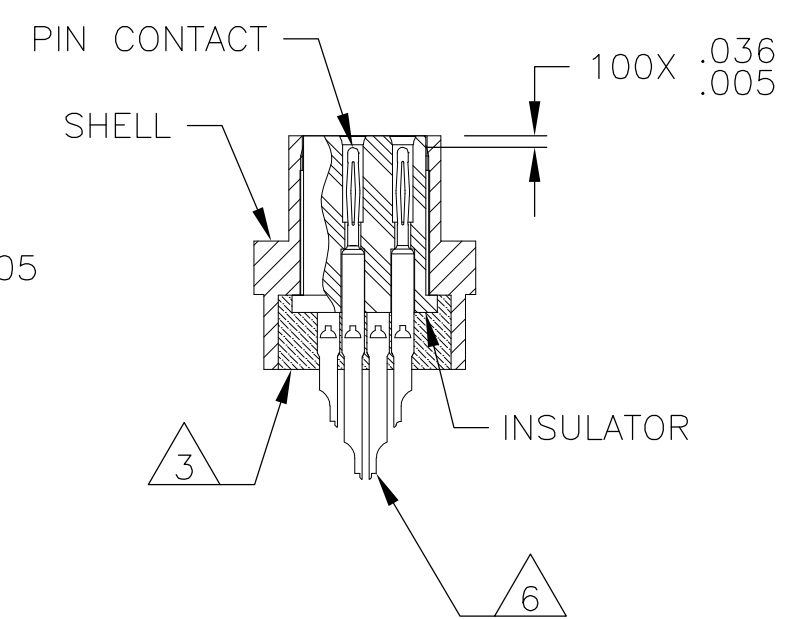
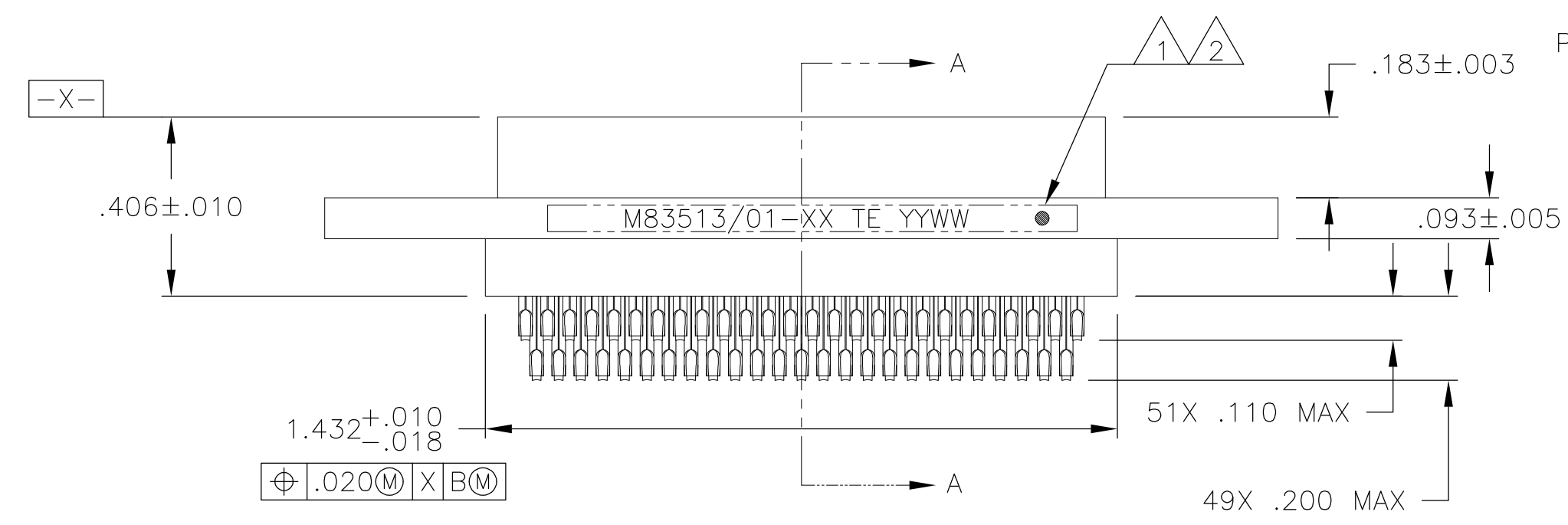
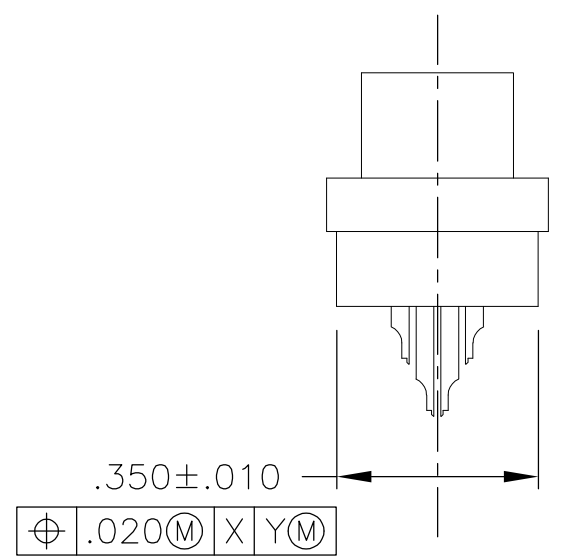
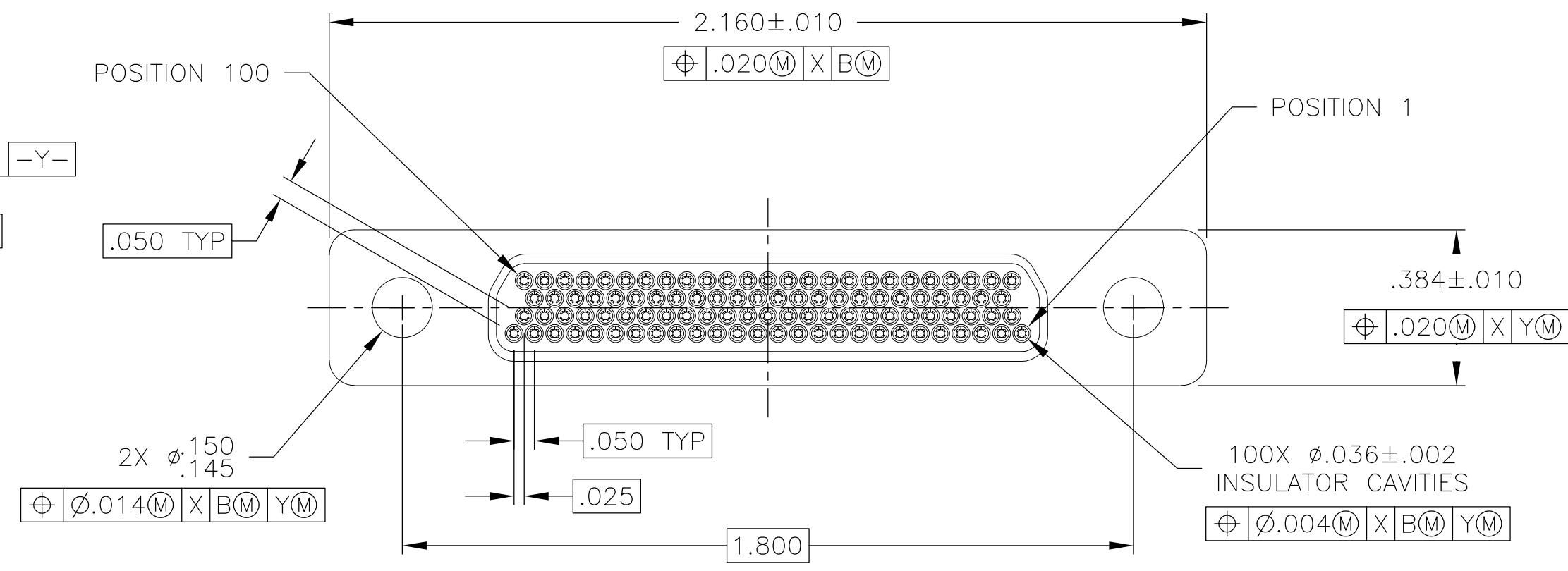
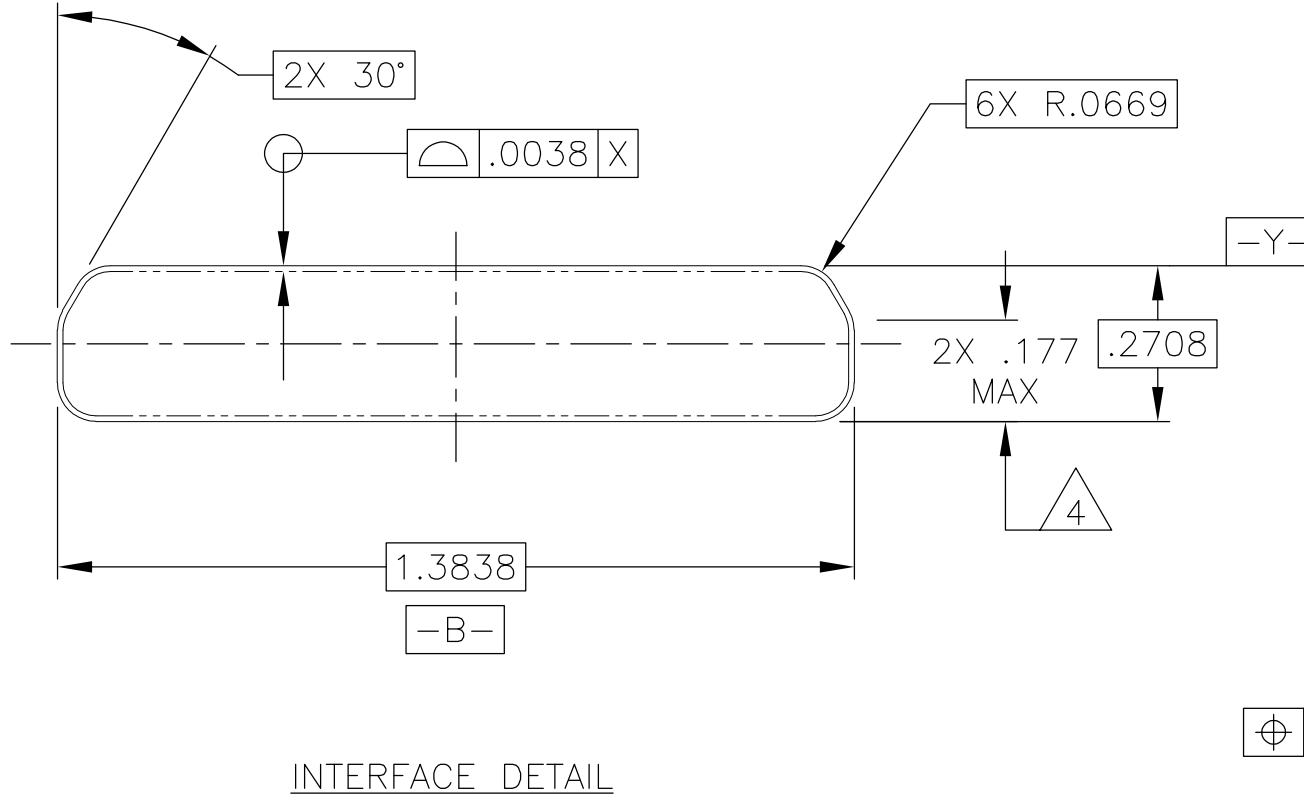

- 1 CONNECTOR SHALL BE MARKED IN ACCORDANCE WITH METHOD I OF MIL-STD-1285. MARKING SHALL CONTAIN THE MILITARY PIN, CAGE CODE (OR TE), AND DATE CODE. EXAMPLE: M83513/01-XX TE YYWW (WHERE XX IS PART OF THE PIN SHOWN IN THE "MIL-DTL-83513" COLUMN OF THE PART NUMBER TABLE, AND YYWW IS THE DATE CODE). TEXT HEIGHT SHALL BE .035 INCH MINIMUM.
- 2 POSITION 1 SHALL BE INDICATED BY AN IDENTIFIABLE MARK, LOCATED APPROXIMATELY AS SHOWN ON THE POSITION 1 SIDE OF THE CONNECTOR FLANGE. THIS MARK SHALL BE INCLUDED AS PART OF THE PART MARKING INFORMATION.
- 3 EPOXY ENCAPSULATION. EPOXY MAY WICK .050 INCH MAX FOR SOLDER CUPS.
- 4 THIS DIMENSION IS THE THEORETICAL INTERSECTION OF THE TWO ADJACENT SIDES OF THE INTERFACE
- 5 ALL DIMENSIONS AND REQUIREMENTS ARE PER MIL-DTL-83513/1
- 6 CHAMFER ON SOLDER POTS ARE PARALLEL WITH THE SIDE OF CONNECTOR WITHIN 10°

THIS DRAWING IS A CONTROLLED DOCUMENT.		DWN B. ROMANCHUK 03 SEP 08																				
DIMENSIONS: INCHES		CHK M. STORRY 03 SEP 08																				
TOLERANCES UNLESS OTHERWISE SPECIFIED:		APVD M. STORRY 03 SEP 08	NAME PLUG ASSEMBLY, MICRO-D PER MIL-DTL-83513/01, MCKS SERIES, 100 POSITION																			
<table border="0"> <tr><td>0 PLC</td><td>±</td><td>-</td></tr> <tr><td>1 PLC</td><td>±</td><td>-</td></tr> <tr><td>2 PLC</td><td>±</td><td>.010</td></tr> <tr><td>3 PLC</td><td>±</td><td>.005</td></tr> <tr><td>4 PLC</td><td>±</td><td>-</td></tr> <tr><td>ANGLES</td><td>±</td><td>1°</td></tr> </table>		0 PLC	±	-	1 PLC	±	-	2 PLC	±	.010	3 PLC	±	.005	4 PLC	±	-	ANGLES	±	1°	PRODUCT SPEC APPLICATION SPEC	SIZE A2	CAGE CODE 98278
0 PLC	±	-																				
1 PLC	±	-																				
2 PLC	±	.010																				
3 PLC	±	.005																				
4 PLC	±	-																				
ANGLES	±	1°																				
MATERIAL SEE NOTES		FINISH -	DRAWING NO 1532216	RESTRICTED TO -																		
		WEIGHT -	SCALE 4:1	SHEET 1 of 2																		
		CUSTOMER DRAWING	REV B																			

